

ANSI code 18  
Type EPN-110DN

- **Control of electronic governors**
- **Setting of integrating time**
- **Adjustment of output signal**
- **Offset adjustment**
- **LED indication for activated input**
- **35 mm DIN rail or base mounting**

### Application

The electronic potentiometer type EPN-110DN forms part of a complete DEIF series of relays for protection and control of generators, and is applicable to both marine and land-based installations.

The EPN-110DN is type approved by major classification societies and is an electronic unit to replace normal motor potentiometers.

The potentiometer converts the relay output of a PI step controller - e.g. one of the DEIF load sharing units type LSU.. or one of the DEIF synchronisers type FAS., or any other type of PI step controller provided with relay outputs - to a control voltage for the speed governor/AVR.

### Measuring principle

The EPN-110DN is provided with 3 inputs:

- “▲” (frequency or voltage increase)
- “▼” (frequency or voltage decrease)
- “RES” (reset of the unit).

**Note:** During power up the potentiometer is automatically reset.

On activation of one of the inputs “▲” and “▼”, the analog output of the potentiometer to the speed governor/the AVR is changed correspondingly.

The EPN-110DN is furthermore provided with an offset adjustment for change of the point where the control loop starts and to which the unit returns after reset. Both the output signal, the rate of change of this (the integrating time) and the offset are set on potentiometers on the front of the EPN-110DN.

### Outputs/settings

The EPN-110DN is equipped with 2 LED indicators on the front of the unit, which are lit when their input (“▲” and “▼” respectively) has been activated.

To ensure that the EPN-110DN can be connected to all common electronic speed governors and AVR's, the analog output of the EPN-110DN has been designed as a current generator shunted by a 500Ω potentiometer.

#### Output signal

Potentiometer “OUTPUT” (0...±1V DC x 1, x 5 or x 10)

## Electronic potentiometers

uni-line

4921240126E

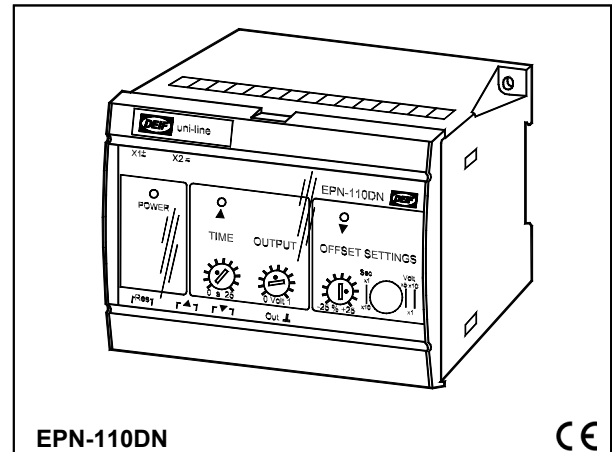

The maximum and minimum change of the frequency/voltage of the connected speed governor/AVR, controlled by the EPN-110DN.

The range (“x 1”, “x 5” or “x 10”) is selected by means of 2 DIP switches accessible from the front of the relay.

A special output 0...5...10V DC is available for interfacing between a DEIF synchroniser type FAS-115DG and a var load sharing unit type LSU-122DG, applied for voltage adaption to obtain simultaneous synchronisation of all generators of a plant to the busbar.

#### Integrating time

Potentiometer “TIME” (2.5 s...25 s x 1 or x 10)

How quickly the output integrates from the minimum to the maximum setting (or vice versa). This setting thus determines how quickly e.g. a load sharing will be carried out.

The range (“x 1” or “x 10”) is selected by means of a DIP switch accessible from the front of the relay.

#### Offset

Potentiometer “OFFSET” (-25...0...25% of output)

The point where the control loop starts. This setting determines e.g. to which frequency the generator should be reset instantaneously during power-up or on activation of the reset input.

### Principle diagram

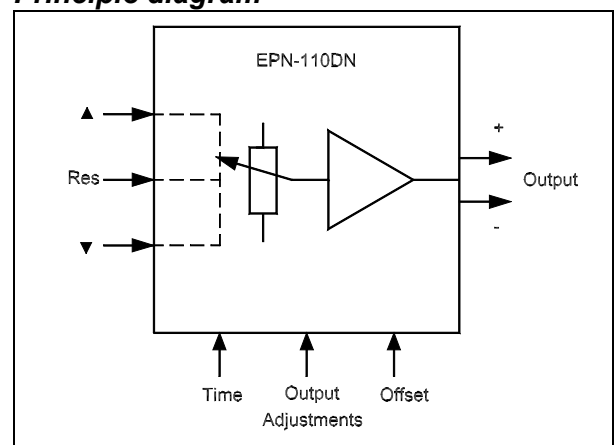

## Type EPN-110DN

### Technical specifications

<b>Relay input:</b>	Potential-free relay contacts open contact: 15V DC closed contact: 4mA
<b>Analog output:</b>	0...±1V DC (DIP switches set to "x1") or: 0...±5V DC (DIP switches set to "x5") or: 0...±10V DC (DIP switches set to "x10")
output resistance:	0...500Ω potentiometer.
<b>Offset adjustment:</b>	-25...0...25% of output.
<b>Ripple:</b>	Max. 5mV RMS.
<b>Resolution:</b>	5mV DC (12-bit D/A converter).
<b>Response time:</b>	<100 ms, input to output.
<b>Temperature:</b>	-25...70°C (operating).
<b>Temperature drift:</b>	Set points: max. ±0.2% of full scale per 10°C.
<b>Galvanic separation:</b>	3250V - 50Hz - 1 min. Supply voltage to other circuits.  None between inputs and DC output.
<b>Supply voltage (U<sub>n</sub>):</b>	57.7-63.5-100-110-127-200-220-230- 240-380-400-415-440-450-660-690V AC ±20% (max. 3.5VA)  24-48-110-220V DC -25/+30% (max. 2W).
<b>Climate:</b>	HSE, to DIN 40040.
<b>EMC:</b>	To EN 50081-1/2, EN 50082-1/2, SS4361503 (PL4) and IEC 255-3.
<b>Connections:</b>	Max. 4mm <sup>2</sup> (single-stranded). Max. 2.5mm <sup>2</sup> (multi-stranded).
<b>Materials:</b>	All plastic parts are self-extinguishing to UL94 (V1).
<b>Protection:</b>	Case: IP40. Terminals: IP20, to IEC 529 and EN 60529.
<b>Type approval:</b>	The uni-line components are approved by the major classification societies. For current approvals see www.deif.com or contact DEIF A/S.

### Settings

Setting of	Range
Integrating time:	2.5 s...25 s or 25...250 s
Output:	-1...0...1V DC, -5...0...5V DC or -10...0...10V DC
Offset:	-25...0...25% of output

### Indication

LED	Light
"▲" (Increase)	Yellow, when relay is activated
"▼" (Decrease)	

The relay is furthermore equipped with a green LED marked "POWER" for indication of power ON.

Once the relay has been mounted and adjusted, the transparent front cover may be sealed, preventing unwanted change of the setting.

### Connections/dimensions (in mm)

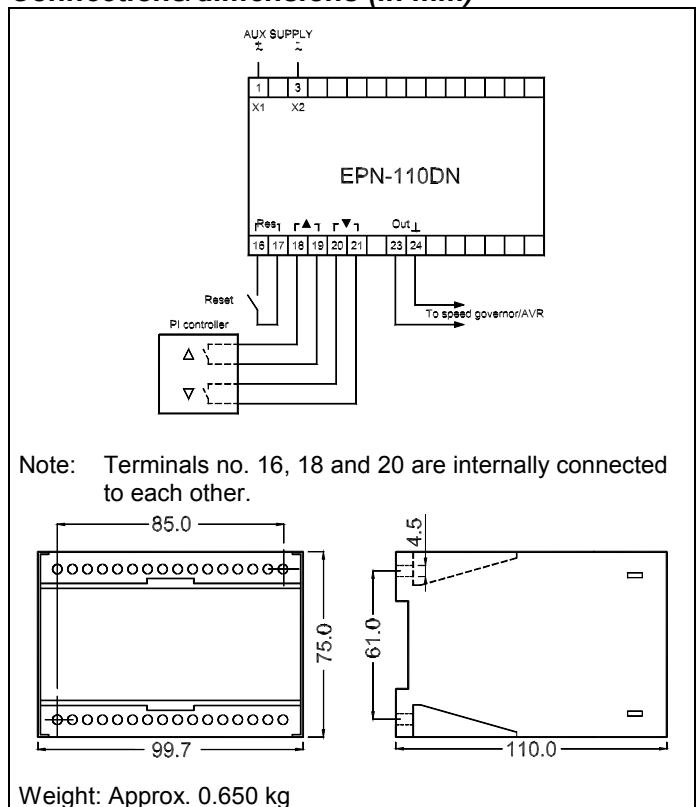

### Order specifications

**Type - (Output)\* - Supply voltage**  
 Example: EPN-110DN -5...0...5V DC - 24V DC  
 \*) Specify if non-standard

Due to our continuous development we reserve the right to supply equipment which may vary from the described.



DEIF A/S, Frisenborgvej 33  
DK-7800 Skive, Denmark

Tel.: +45 9614 9614, Fax: +45 9614 9615  
E-mail: deif@deif.com, URL: www.deif.com

