

Standard functions

Engine control

- Start preparation (preheater or prelubrication)
- Start/stop sequences with selectable no. of start attempts
- Fuel solenoid selection (coil type)
- Idle speed control
- Local or remote start/stop
- Stop sequence with cool down
- Running speed detection selectable
 - Charger alternator input (W terminal) (option)
 - Binary input

Applications

- Automatic engine start/stop
- Engine protection

Engine monitoring

- 3 configurable inputs (option)
 - VDO or
 - 4-20mA from active transducer or
 - Binary with cable supervision
- 6 binary inputs, configurable
- RPM input, selectable (option)
 - Magnetic pick-up
 - NPN or PNP pick-up
 - Tacho generator
 - Charger alternator W terminal

Clear text display

- 122 x 32 pixel back-light STN
- Graphic symbol messaging
- Clear text alarm messages
- Clear text diagnostics for both hardwired inputs and CAN bus messages (J1939)
- Log book holding 30 log entries

Application

The Engine Controller EC-1M is a micro-processor based control unit containing all necessary functions for protection and control of a diesel engine. Furthermore, it contains a single-phase AC voltage measuring circuit. The unit is equipped with an LCD display presenting all values and alarms. EC-1M is a compact all-in-one unit designed for the following applications:

1. Automatic engine start/stop
2. Engine protection

Optional applications:

3. Generator voltage and frequency supervision

EC-1M automatically carries out a cyclical self test. If any errors are found, then the status relay output will deactivate (normally closed). In order to save battery power, the display can be set to switch off automatically after a given period of time. The display will turn on again, if events or alarms take place, or if one of the push-buttons is activated.

Setup

Setup is easily done via a PC Windows® based utility software (password protected) using the RJ45/RS232 PC connection. The PC interface box RJ45/RS232 needed for this operation is optional equipment for EC-1M. The PC utility software offers additional features such as monitoring of all relevant information during commissioning, saving and downloading of settings and downloading of software updates. Furthermore, the most often used settings can be accessed via the display push-buttons (password protected).

Options

In order to perfectly match EC-1M to specific applications, the unit can be equipped with a number of available options. The options selected by the customer will be integrated in the standard EC-1M hereby securing the same user interface unaffected by whether the application needs a basic or a more complex engine controller.



For approved installations, care must be taken to comply with the rules. In certain cases, additional engine protection equipment may be required. If in doubt, contact the classification society in question.

Terminals

Terminal	Technical data	Description
10...11	Status out. Contact ratings 1 A 30V DC/V AC	General status output for marine approvals
12	Common	Common for term. 13...18
13	Digital input	Start enable/configurable
14	Digital input	Remote start/configurable
15	Digital input	Charge alternator D+ (running)/configurable
16	Digital input	Overspeed/configurable
17	Digital input	Coolant temperature/configurable
18	Digital input	Oil pressure/configurable
23	Common	Common for term. 24, 25 and 32 and emergency stop*
24	Relay output 1. Contact ratings 2 A 30V DC/V AC	Horn. Function NO
25	Relay output 2. Contact ratings 2 A 30V DC/V AC	Alarm/configurable. Function NO
26	Power supply –	GND
27	Power supply +	5...36V DC
28...31	Not used	Note 23 and 31 is internally connected
32	Relay output 3. Contact ratings 2 A 30V DC/V AC	Start prepare/configurable. Function NO
33-34	Relay output 4. Contact ratings 8 A 30V DC/V AC	Run coil/stop coil/configurable. Function NO
35-36	Relay output 5. Contact ratings 8 A 30V DC/V AC	Starter (crank)/configurable. Function NO
Optional configurable inputs (option M17)		
4	Common	Common for term. 5...7
5	VDO1/4...20mA/binary input	Fuel level/configurable
6	VDO2/4...20mA/binary input	Oil pressure/configurable
7	VDO3/4...20mA/binary input	Water temp./configurable
Optional CAN bus #1 engine interface (option H5)		
1	Can-GND	CAN J1939 engine communication
2	Can-L	
3	Can-H	

Terminal	Technical data	Description
Optional tacho RPM input (option M17)		
8	Tacho-GND	Magnetic pick-up. PNP or NPN/tacho generator/charge alternator W terminal
9	Tacho input	
Optional single-phase generator voltage input (option B2)		
19	L2 or N	Generator voltage and frequency
20	Not used	
21	L1	
22	Not used	

Available options

Option	Description	Type	Note
B	Generator protection		
B2	Single-phase (L-L or L-N), 50 – 550V AC, 50/60Hz - Single-phase over- and undervoltage (27/59) - Single-phase over- and underfrequency (81)	Software option	
G	Control functions		
G6	Generator breaker control. See the display front layout below	Hardware option	Requires B2
H	Communication		
H1	CAN open communication	Hardware option	
H5	CAN bus J1939 - Detroit Diesel DDEC - John Deere JDEC - Deutz EMR - Volvo Penta D12 AUX - Scania EMS	Hardware option	
J	Cables		
J5	PI-1 converter box kit (for PC connection)	Hardware option	
K	Installation Instructions and Reference Handbook		
K1	Installation Instructions and Reference Handbook (hard copy)	Other	
K2	Installation Instructions and Reference Handbook (CD-rom)	Other	
L	Gasket for IP 54	Hardware option	
M	Input options		
M17	3 configurable VDO, 4...20mA, binary inputs Tacho input (magnetic pick-up, NPN, PNP pick-up, charge generator W input)	Hardware option	
Y	Front folio options		
Y2	Front folio for alarm unit (no start/stop/AUT buttons)	Hardware option	

(ANSI# as per IEEE Std C37.2-1996(R2001) in parenthesis).

Engine Controller (Marine) EC-1M

Option G6 display layout

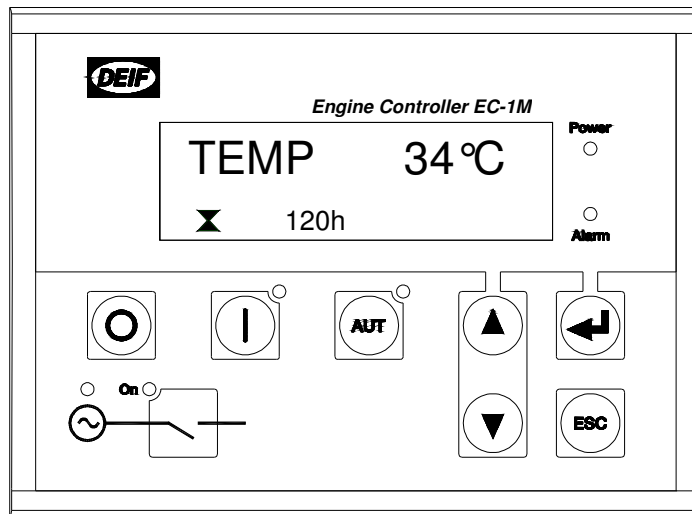

Option Y2 display layout

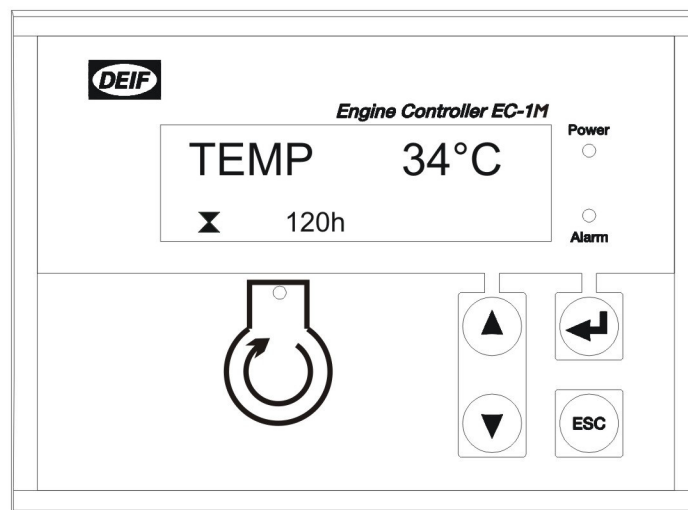

Wiring



F: Fuse: 2A slow-blow.

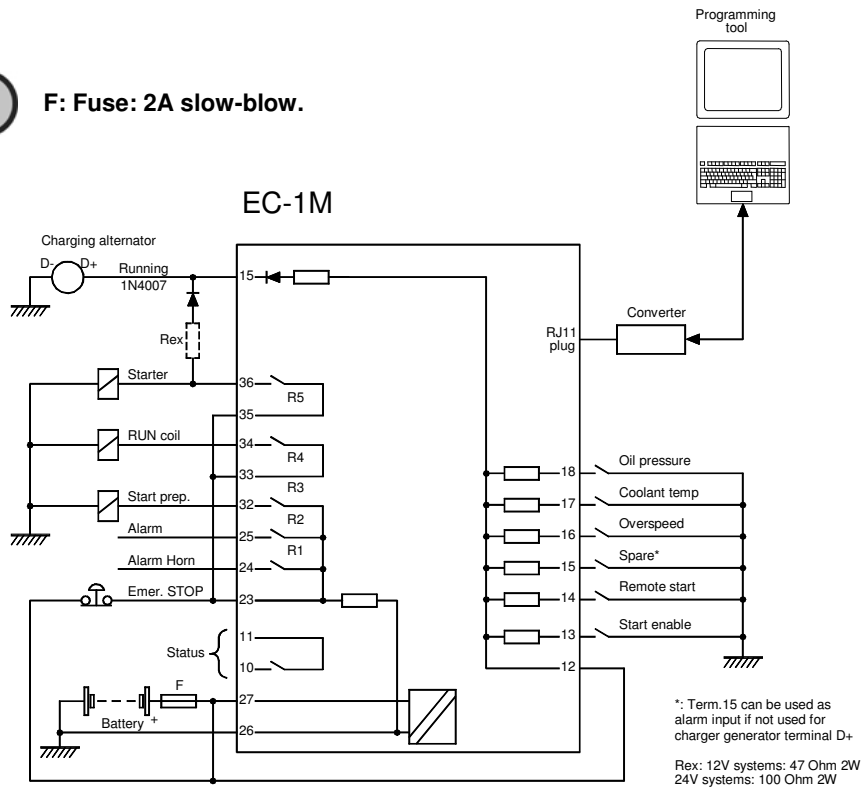

<p>H5 Engine communication</p>		<p>B2 Generator voltage</p>
<p>M17 Multi-functional inputs VDO sensors</p>	<p>M17 Multi-functional inputs 4-20 mA transmitters</p>	<p>M17 Multi-functional inputs Binary input w. cable superv.</p>
<p>M17 Tacho input Magnetic pickup/ Tacho generator</p>	<p>M17 Tacho input NPN/PNP pickup</p>	<p>M17 Tacho input W input from charger alternator</p>

Technical specifications

Accuracy:	Class 2.0 to EN 60688/IEC 688	Impedance:	240Ω ~ 16mA
Operating temp.:	-25...70 °C	Relay outputs:	
Storage temp.:	-40...70 °C	3 relays:	30V DC/AC 2A
Measuring input voltage:		2 relays:	30V DC/AC 8A
	50...550V AC phase to phase	1 status relay:	24V DC 1A
Load:	1.5MΩ	Mounting:	Panel mounted
Frequency:	30...70Hz	Size:	78 x 106 mm
Pick-up input voltage:		Climate:	Class HSE, to DIN 40040
Frequency:	0.5...70V peak 10-10000Hz	Display:	122 x 32 pixel back-light STN
Aux. supply:	4-36V DC continuously Max. 8W consumption	Safety:	To EN 61010-1, installation category (overvoltage category) III, 600V, pollution degree 2
Passive binary in voltage:		Protection:	Front: IP 52 (IP 54 with gasket, option L) Terminals: IP20 To IEC 529 and EN 60529
	Bi-directional optocoupler 8...36V DC	EMC/CE:	To EN 61000-6-1/2/3/4 SS4631503 (PL4) and IEC 255-3
Impedance:	4.7kΩ	Material:	All plastic materials are self- extinguishing according to UL94 (V1)
VDO inputs:	Resistor inputs, internal 4V supply	Plug connections:	AC voltage inputs: 3.5 mm ² multi stranded Other: 1.5 mm ² multi stranded
Analogue input:	From active transducer	PC connection:	RS232 converter box (option J5)
Current:	4...20mA	Approval:	CE & C-UL (listing pending) Major classification societies (see www.deif.com for details)
Impedance:	50Ω	Weight:	Approx. 0.7 kg (1.5 lbs)
Active binary in internal voltage:			
	Dry contact inputs (note 1) 4V DC supply, with cable supervision		



Note 1: Only 3 inputs are available.



It is possible to combine VDO inputs with binary and 4...20mA inputs in a mix.

Unit dimensions

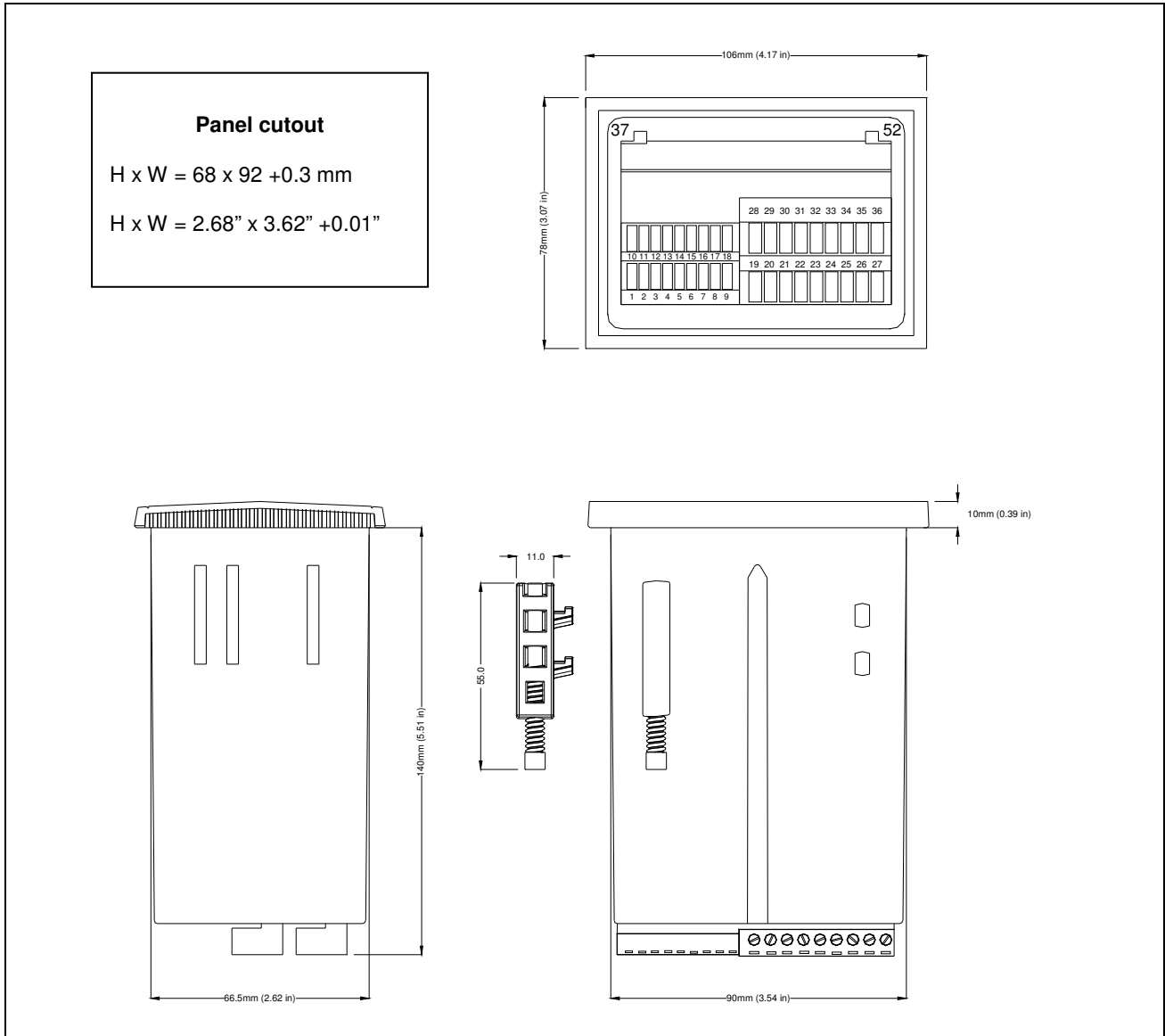

Order specifications

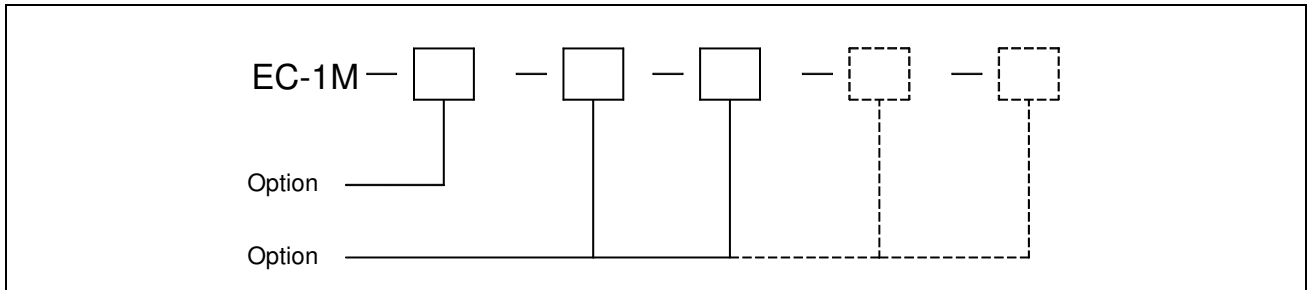

Due to our continuous development we reserve the right to supply equipment which may vary from the described.



DEIF A/S, Frisenborgvej 33
 DK-7800 Skive, Denmark

Tel.: +45 9614 9614, Fax: +45 9614 9615
 E-mail: deif@deif.com, URL: www.deif.com

