

### Standard functions

#### Applications

- AMF (no synchronising)
- Island mode (stand alone)

#### Generator controls

- Engine start/stop
- Configurable start sequence

#### Protection and I/Os (ANSI)

- Reverse power (32)
- Overcurrent, 2 levels (51)
- 3 configurable VDO inputs
- 1-5 configurable digital inputs
- 1-3 configurable outputs

#### Display

- Status texts
- Easily readable
- Password-protected setup
- Configurable views
- Complete alarm list
- Event log (150 events)
- Language configuration

#### M-logic

- Simple logic configuration tool
- Selectable input events
- Selectable output commands

#### Measurement system

- 3-phase true RMS (100-480V AC)
- Supports delta V applications
- -/1 and -/5A AC
- 100-25000V AC trafo ratios

#### Breaker types

- Contactor
- Circuit breaker
- Compact breaker

#### General

- Approval: Gost-R
- PC software available
- Additional functions available
- Additional applications available
- Additional I/Os available

**Application**

The Basic Gen-set Controller is a microprocessor-based control unit containing all necessary functions for control and protection of a gen-set and control of mains and generator breaker. The standard control functions include start and stop sequences for the engine, but regulation control is also possible. The BGC contains all necessary 3-phase measuring circuits and all values and alarms are presented on the LCD display.

The BGC is a compact all-in-one unit designed for the following standard and optional applications:

*Standard applications: (no synchronising)*

1. Automatic mains failure (no back sync.)
2. Island operation

*Optional applications: (synchronising)*

3. Multiple gen-sets, load sharing
4. Peak shaving
5. Fixed power to mains
6. Automatic mains failure (back sync.)
7. Load take over

The optional applications require governor/AVR control for parallel operation. (option G2 or G3).

The generator and mains breaker types can be configured to be either a circuit breaker, a contactor or the compact breaker which requires a signal to reset the breaker from tripped to open position.

**Configurable inputs/outputs:**

The BGC is supplied with a standard number of inputs and outputs that can be used for control and/or protection purposes. The number of configurable I/Os depends on the used breaker type.

The table *only* shows available I/Os for the standard unit (no hardware options are selected.) This means that additional I/Os can be selected (please refer to the option list for more).

I/O \ PCB	Circuit breaker	Contactor	Compact breaker
MPU (Tacho)	1	1	1
Digital inputs	9 (5)	9 (7)	9 (5)
VDO	3	3	3
Relay outputs	9 (1)	9 (3)	9 (1)



The number in parenthesis indicates the number of user configurable digital inputs/relay outputs. (Horn output, start/stop functionality and breaker handling occupies the I/Os not freely configurable).

Additional I/Os can be selected.



Example: BGC - M13.2 - M14.3 gives an **additional 7 digital inputs/4 digital outputs**. Please see the option list and hardware overview in this data sheet.

**Governor and AVR control**

Speed governor control and automatic voltage regulation are optional functions and can be analogue or digital. (Both digital AVR + GOV outputs requires a total of 4 relay outputs. Note that 3-13 relays are available depending on options and breaker selection.

**Setup**

Setup is easily done via a menu structure in the display (password protected, 3 levels) or via the RJ45/RS232 PC connection and the multi-line 2 Windows® based PC utility software. The PC interface box needed for this operation is optional equipment for the BGC. The utility software offers additional features such as monitoring of all relevant information during commissioning, saving and downloading of settings and downloading of software updates.

**Options**

In order to perfectly match the product solution to specific applications, the functionality of the BGC can be equipped with a number of available options. The options selected by the customer will be integrated in the standard BGC hereby securing the same user interface unaffected by whether the application needs a highly complex or a more basic gen-set controller.

**Display variants**

Two display variants are available for the BGC unit. The unit is normally supplied with the AMF folio.

**AMF folio**

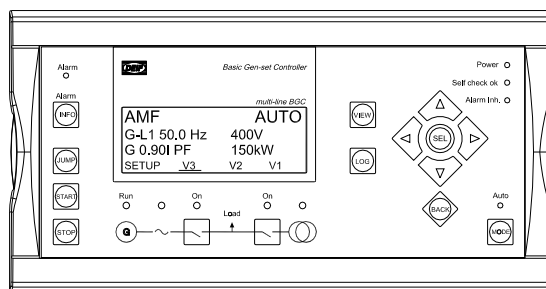

If the unit is used in island applications, the island folio is selectable (Specify option Y1).

**Island folio**

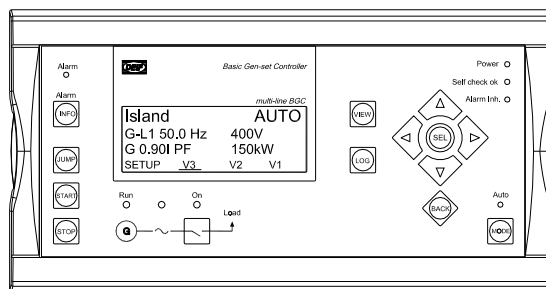

Single line application diagrams

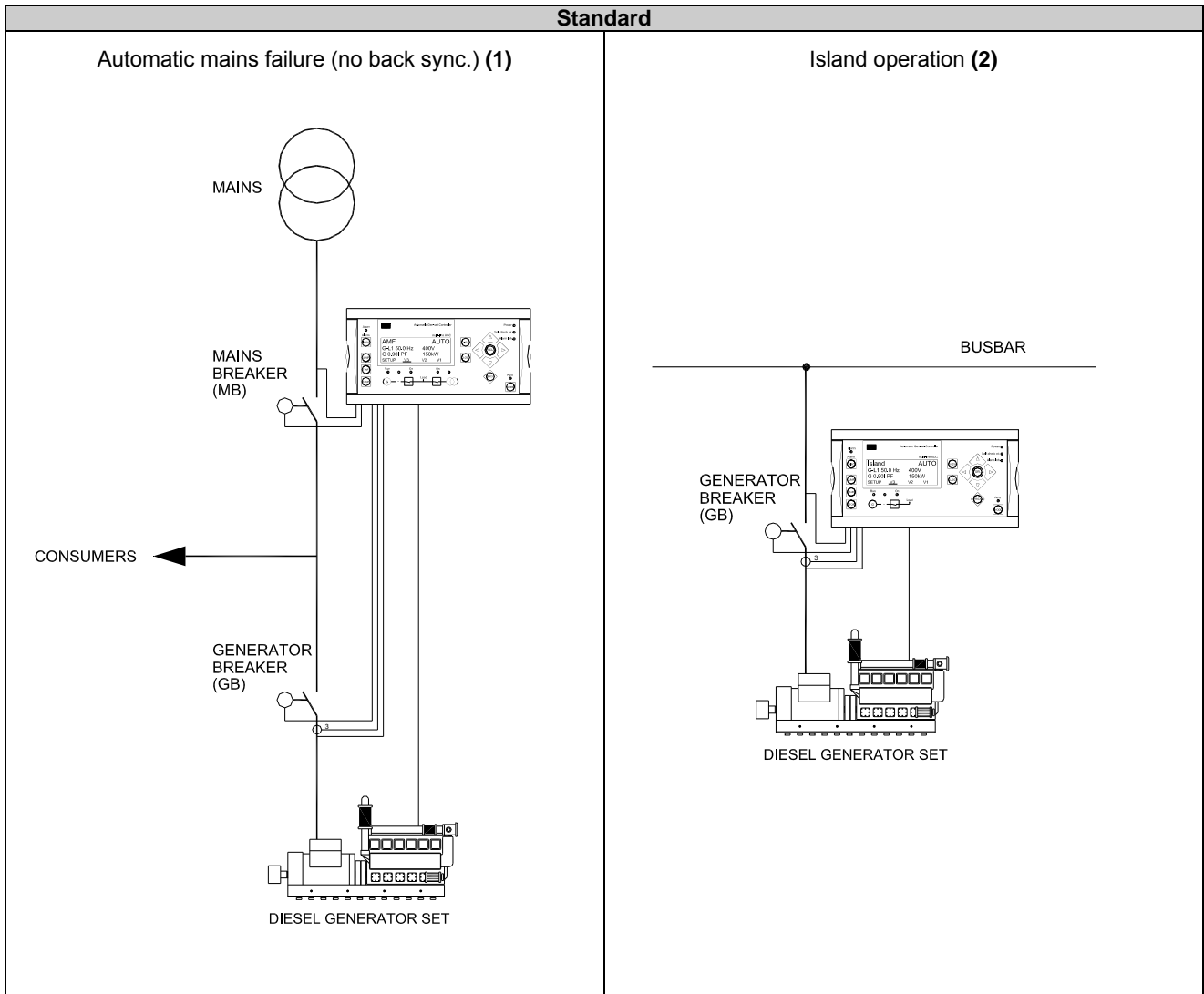

Optional

Multiple gen-sets, load sharing (3)

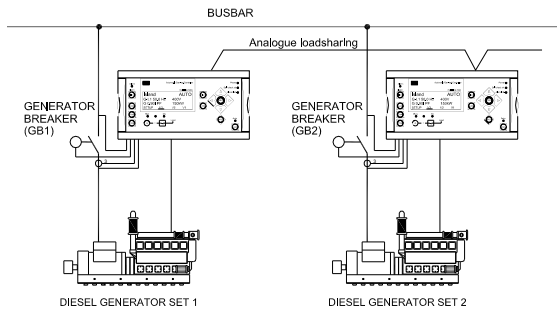

Peak shaving, load take over (4/7)

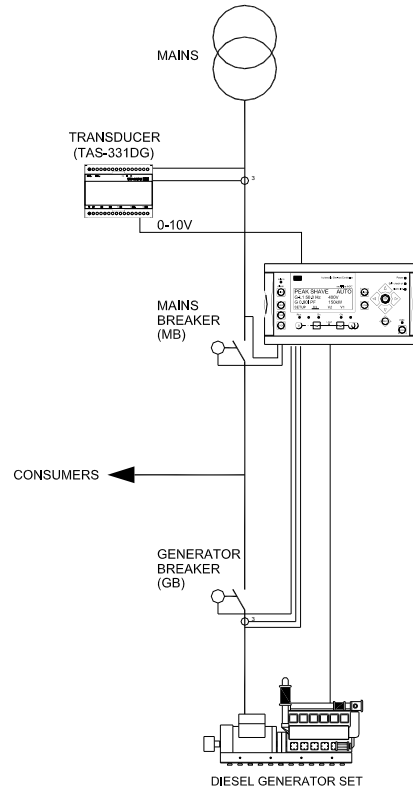

Fixed power to mains (5)

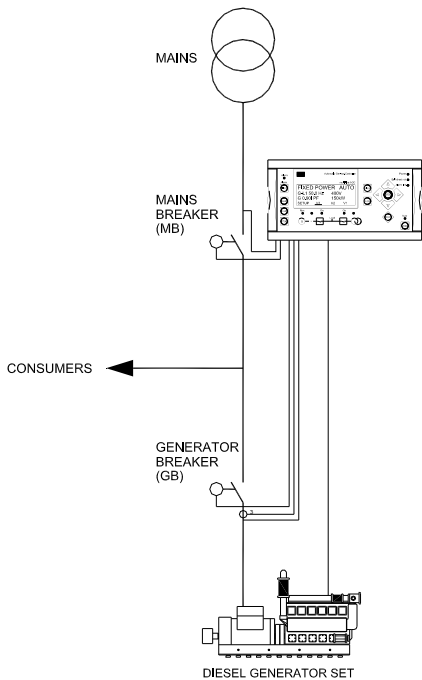

Automatic mains failure (back sync.) (6)

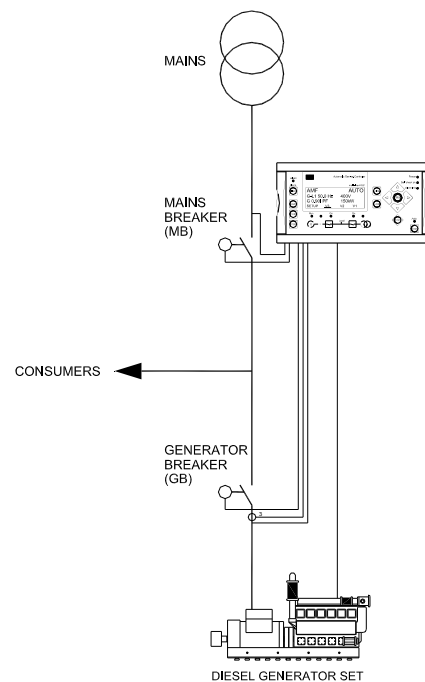

## Available options



Option slot #4 is allocated to options G2 and G3 only. The two remaining slots (#2 and #3) can hold a maximum of two hardware options per unit.

Option	Description	Type	Note
<b>A</b>	<b>Loss of mains protection package</b>		
A1	Over- and undervoltage (generator and busbar/mains) (27/59) Over- and underfrequency (generator and busbar/mains) (81) Vector jump (78) df/dt (ROCOF) (81)	Software option	
A2	Over- and undervoltage (generator and busbar/mains) (27/59) Over- and underfrequency (generator and busbar/mains) (81) df/dt (ROCOF) (81)	Software option	
A3	Over- and undervoltage (generator and busbar/mains) (27/59) Over- and underfrequency (generator and busbar/mains) (81) Vector jump (78)	Software option	
<b>B</b>	<b>Generator/busbar/mains protection package</b>		
B1	Over- and undervoltage (generator and busbar/mains) (27/59) Over- and underfrequency (generator and busbar/mains) (81)	Software option	
<b>C</b>	<b>Generator add-on protection package</b>		
C1	Over- and undervoltage (generator) (27/59) Over- and underfrequency (generator) (81) Overload (32) Short circuit (50) Current unbalance (46) Voltage asymmetry (47) Reactive power import (excitation loss) (40) Reactive power export (overexcitation) (40)	Software option	
<b>D</b>	<b>Voltage/var/PF control</b>		
D1	Selection between: Constant voltage control (stand-alone) Constant power factor control (parallel with mains) Reactive load sharing (island paralleling with other generators) Constant reactive power control (parallel with mains (with option H2/H3))	Software option	Option D1 requires option G2 or G3  See note below
D2	Constant voltage (stand-alone/sync.)	Software option	Option D2 requires option G2 or G3  See note below
<b>F</b>	<b>Analogue transducer outputs</b>		
F1	2 transducer outputs, 0...20mA or 4...20mA	Hardware option	
F2	4 transducer outputs, 0...20mA or 4...20mA	Hardware option	Two boards occupied - see hardware overview
<b>G</b>	<b>Control functions</b>		
G1	2 load-dependent relays (high load/low load)	Hardware option	Option M14.X (relay outputs) is included
G2	Synchronising with analogue lines (Option included in G3)	Hardware option	Two other hardware options available  Parallel mains operation
G3	Synchronising with analogue lines and kW load sharing (G3 includes all functionality contained in option G2)	Hardware option	Two other hardware options available  Parallel mains operation/ parallel DG operation

**Note regarding option D1 and D2:**  
Analogue output for AVR is included on terminals 63/64.



When relay control is needed please check the I/O list to ensure that a sufficient number of relays are available. D1 or D2 follows option G2/G3 and 3-5 relays are available depending on the breaker configuration. Option M14.X offers extra relay outputs that can be used for controlling of the governor and AVR.

## Available options (continued from page 5)

Option	Description	Type	Note
<b>H</b>	<b>Serial communication</b>		
H1	CAN-open	Hardware option	
H2	Modbus RTU	Hardware option	
H3	Profibus DP	Hardware option	
H4	CAT CCM	Hardware option	
H5	CAN-bus (J1939 + MTU) engine communication: MTU MDEC Detroit Diesel DDEC Deutz EMR John Deere JDEC Scania EMS 1&2 Volvo Penta EMS 1&2	Hardware option	
H6	Cummins ECM (RS485) engine communication	Hardware option	
<b>J</b>	<b>Cables</b>		
J5	BGC converter box kit	Other	
<b>K1</b>	<b>Designer's reference handbook (hard copy)</b>	Other	CD rom encl. at delivery
<b>L</b>	<b>Gasket</b>	Other	Display IP 54
<b>M</b>	<b>Configurable I/O extension cards</b>		
M13.X	7 binary inputs, configurable	Hardware option	Can be placed in both slot 2 and 3 if 14 extra binary inputs are needed
2M13	14 binary inputs	Hardware option	Same as M13.2/M13.3 Occupies slot 2 and 3
M14.X	4 relay outputs	Hardware option	Can be placed in both slot 2 and 3 if 8 extra relay outputs are needed
2M14	8 relay outputs	Hardware option	Same as M14.2/M14.3 Occupies slot 2 and 3
M15	4 analogue inputs, configurable, 4...20mA	Hardware option	
<b>Y</b>	<b>Display layout</b>		
Y1	BGC display for island operation (no mains breaker)	Hardware option	

(ANSI# as per IEEE Std C37.2-1996(R2001) in parenthesis).

**Specification of options M13.X and M14.X:**



.X signifies the slot position. M13.2 therefore means that this option is placed in slot #2 and M13.3 means that this option is placed in slot #3.

Hardware overview



There can only be one hardware option in each slot. This means that slot 2 and 3 can hold one or two options only, never three. Example given: option G1 and F1 can be ordered but not G1, F1 and H1.

Besides the hardware options shown on this page, it is possible to select the software options mentioned in the options overview.

Slot #1, term. 1-46 Power supply/I/Os	
<b>Standard:</b>	AC measurements DC supply Digital I/Os VDO inputs RPM (tacho) input

Slot #2, term. 47-54 Slot #3, term. 55-63 Option (hardware)	
<b>Option F1:</b>	2 transducer outputs, 0-20/4-20mA
<b>Option F2:</b>	4 transducer outputs, 0-20/4-20mA <i>Occupies slot 2 and slot 3</i>
<b>Option G1:</b>	2 x relay outputs for load dep. start/stop
<b>Option H1:</b>	CAN-open
<b>Option H2:</b>	Modbus RTU
<b>Option H3:</b>	Profibus DP
<b>Option H4:</b>	CAT CCM
<b>Option H5:</b>	CANbus (J1939+MTU)
<b>Option H6:</b>	Cummins ECM
<b>Option M13.X:</b>	7 binary inputs, configurable
<b>Option M14.X:</b>	4 relay outputs
<b>Option M15:</b>	4 analogue inputs Configurable, 4-20mA
<b>Option 2M13:</b>	14 binary inputs <i>Occupies slot 2 and slot 3</i>
<b>Option 2M14:</b>	4 relay outputs, <i>Occupies slot 2 and slot 3</i>

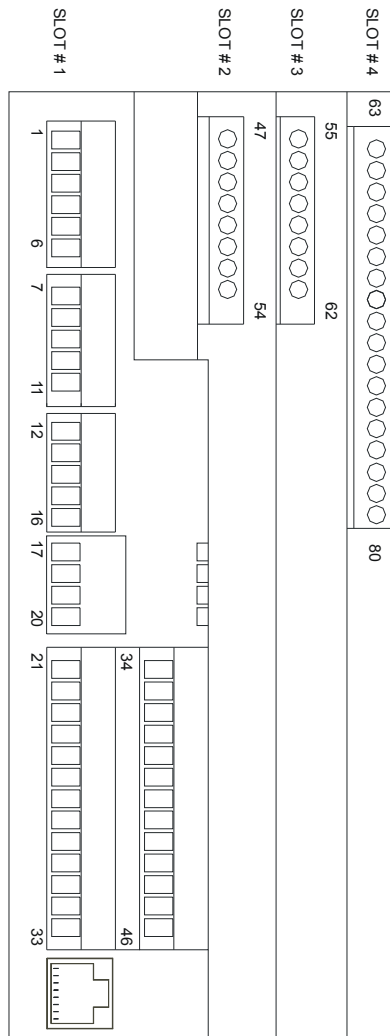

RJ45 connection PC service port, option J5	
<b>PC inter- face:</b>	Converter box complete with cables



**M13.X and M14.X:**  
-X indicates slot position.

(Can be selected for slot #2 and slot #3 at the same time).

Slot #4, term. 63-80 Synchronising/regulation	
<b>Option G2:</b>	Synchronising and governor control <i>(No load sharing)</i>
<b>Option G3:</b>	Synchronising and governor control <i>(load sharing)</i>

Principle diagram

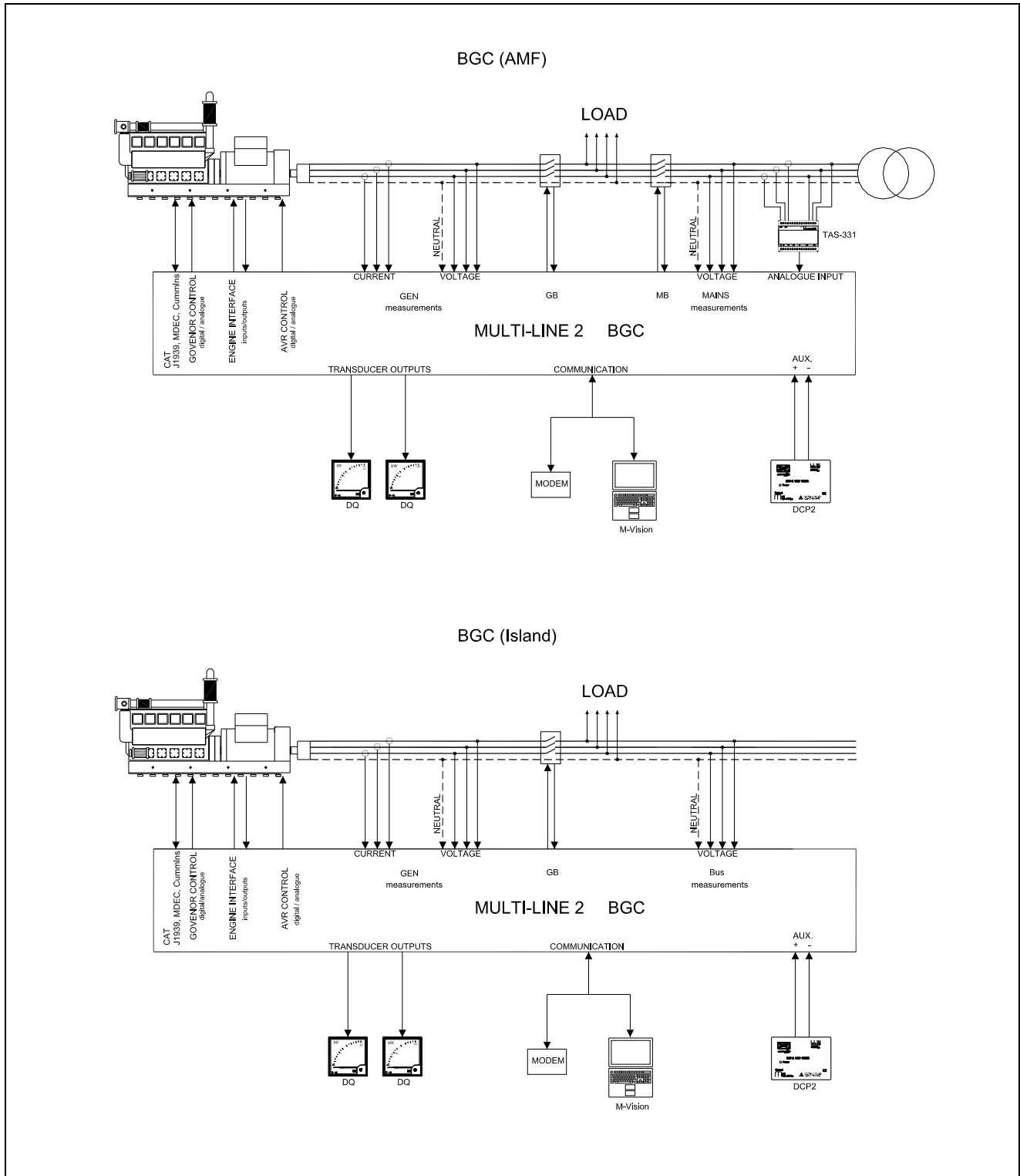

DEIF supplies a complete range of current transformers (**MAK** range of CTs), power supplies (**DCP** range), meters (**DQ** range) and transducers (**TAS** range) that are suitable for use with our range of generator controls and protection relays - please see [www.deif.com](http://www.deif.com) for full details.

## Technical specifications

<b>Accuracy:</b>	Class 1.0, to IEC 688 Short circuit: 5% of 350% * I <sub>N</sub> Analogue outputs: Class 1 of acc. to max. range Acc. to IEC688	<b>Load sharing lines:</b>	+/-5V DC Impedance: 23.5kΩ
<b>Operating temp.:</b>	-25-70°C (-13-158°F)	<b>Analogue outputs:</b>	0(4)-20mA (transducer) and +/-25mA (regulation) Galvanically separated Active output (internal supply) Load max. 500Ω
<b>Galvanic separation:</b>	Between AC voltage, AC current and other I/Os: 2200V AC, 50Hz, 1 min.  Between analogue outputs: 500V DC, 1 min.	<b>Safety:</b>	To EN 61010-1, installation category (overvoltage category) III, 600V, pollution degree 2
<b>Meas. voltage:</b>	100-480V AC +/-20%	<b>Protection:</b>	Unit: IP20 Display: IP52 (IP54 with gasket option L)  Acc. to IEC529 and EN 60529
Consumption:	Max. 0.15VA/phase	<b>EMC/CE:</b>	To EN 61000-6-1/2 SS4631503 (PL4) and IEC 255-3
<b>Meas. current:</b>	-/1 or -/5A AC	<b>VDO inputs:</b>	Resistor inputs, internal supply
Consumption:	Max. 0.3VA/phase	<b>Material:</b>	All plastic materials are self- extinguishing according to UL94 (V1)
<b>Current overload:</b>	4 x I <sub>n</sub> continuously 20 x I <sub>n</sub> , 10 sec. (max. 75A) 80 x I <sub>n</sub> , 1 sec. (max. 300A)	<b>Plug connections:</b>	AC current: 4 mm <sup>2</sup> multi stranded Other: 2.5 mm <sup>2</sup> multi stranded
<b>Meas. frequency:</b>	30-70Hz	<b>PC:</b>	RS232 converter box (option J5)
<b>Aux. supply:</b>	12/24V DC, -25/+30% Max. 8W consumption	<b>Approval:</b>	Gost-R (Russia)
<b>Binary inputs:</b>	Bi-directional optocoupler ON: 5-36V DC OFF: <2V DC Impedance max. 4.7kΩ	<b>Weight:</b>	Approx. 1 kg (2.2 lbs)
<b>Relay outputs:</b>	250V AC / 8A or 24V DC / 2A	<b>Response times:</b>	
<b>Analogue inputs:</b>	+/-10V DC Not galvanically separated Impedance: 100kΩ  4-20mA inputs: Impedance: 50Ω Not galvanically separated  MPU (tacho): 2-70V AC, 10-10000Hz, Impedance: 200kΩ	<i>Busbar 1 and 2:</i>	Over-/undervoltage <50 ms Over-/underfrequency <50 ms
<b>Mounting:</b>	Panel mounted	<i>Generator:</i>	Reverse power: <300 ms Overcurrent: <250 ms Fast overcurrent: <40 ms Over-/undervoltage: <300 ms Over-/underfrequency: <300 ms Overload 1/Overload 2: <1100/300 ms Current unbalance: <300 ms Voltage unbalance: <300 ms React. power import: <300 ms React. power export: <300 ms
<b>Climate:</b>	Class HSE, to DIN 40040	<i>Mains:</i>	ROCOF: 130 ms (4 periods) Vector jump <20 ms

Unit dimensions in mm (inches)

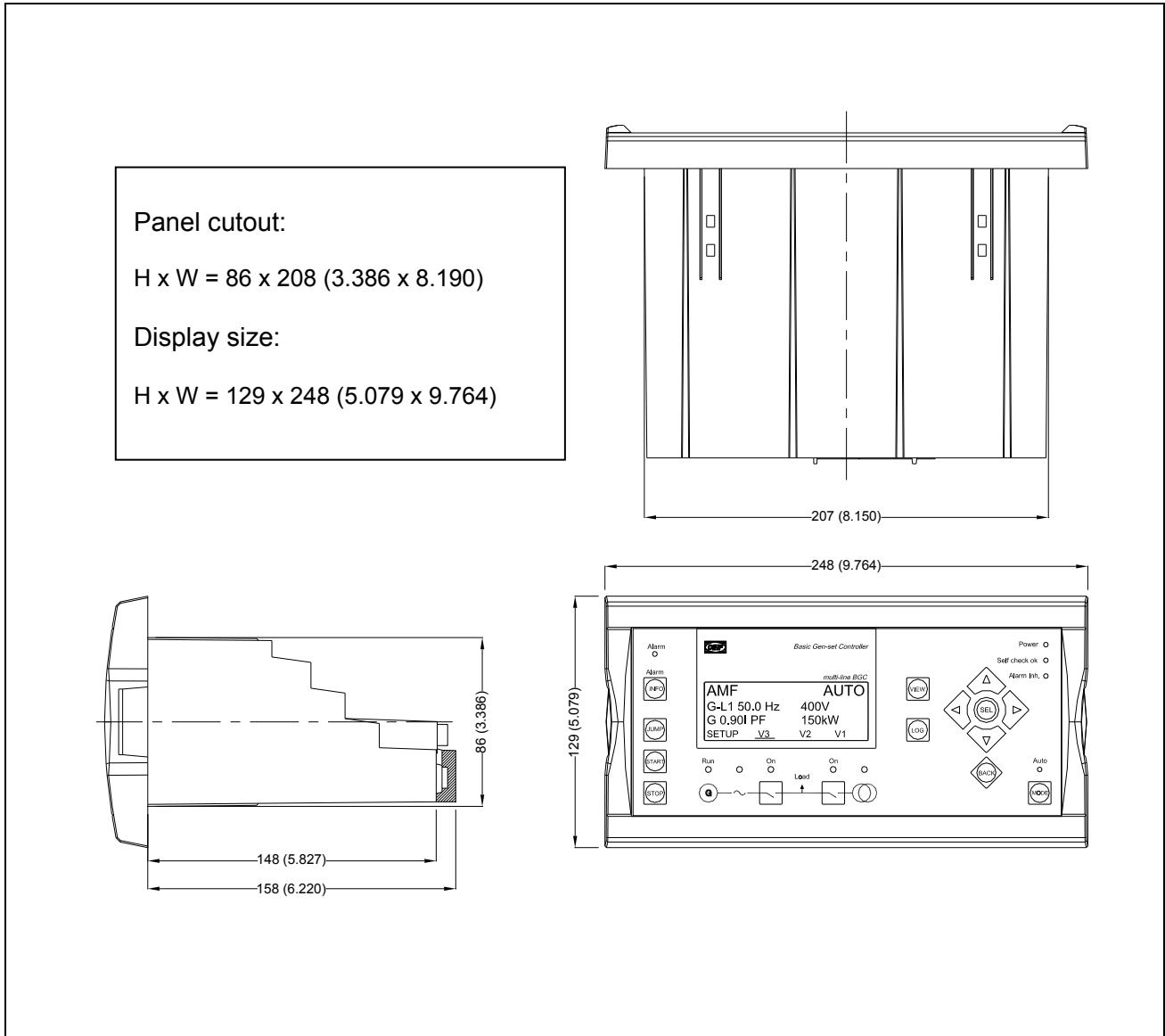

Order specifications

<b>BGC</b>	-	<b>Gen. voltage*</b>	-	1. OPTION	-	2. OPTION	-	3. OPTION	-	4. OPTION	-	SLOT#2	-	SLOT#3
		100-110 or 380-480 VAC												
<b>Order example</b>														
<b>BGC</b>	-	<b>380-480 VAC</b>	-	1. OPTION	-	2. OPTION	-	3. OPTION	-		-	SLOT#2	-	SLOT#3
				<b>A2</b>		<b>G2</b>		<b>H5</b>				<b>-</b>		<b>H5</b>

**Slot position: please indicate your preferred hardware position**

Due to our continuous development we reserve the right to supply equipment which may vary from the described.



DEIF A/S, Frisenborgvej 33  
DK-7800 Skive, Denmark

Tel.: +45 9614 9614, Fax: +45 9614 9615  
E-mail: deif@deif.com, URL: www.deif.com

